



Traffic Gate

The A-SAFE Traffic Gate offers strong and versatile protection across various applications such as goods in/out access and loading bay protection.

It has been designed with ease of use in mind by utilising a gas assisted mechanism that ensures the weight of the rail is always supported. When in a closed position, the rail is secured by a pin to ensure maximum stability and strength during impacts.

Available in 3 different sizes to suit a range of workplace applications.

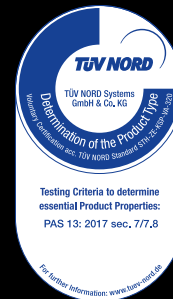



MEMAPLEX™

Ultimate Strength Polymer

created from an exclusive composition of the most sophisticated polyolefins and rubber additives, expertly blended for unequalled strength and flexibility.

Advanced Engineering Molecular

reorientation during manufacturing creates a unique built-in memory that enables the Traffic Gate to fully recover following impacts.

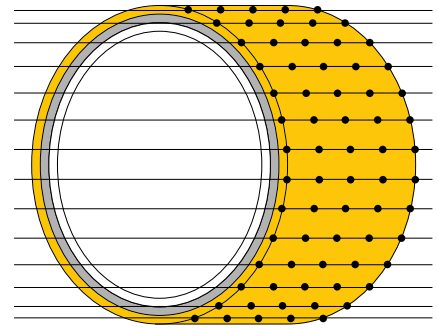

Revolutionary 3-Layered Material

- Inner strengthening core
- Central impact absorption zone
- Outer UV stabilised colour layer

Suitability

Vehicle



Manual pallet truck Electric pedestrian truck Electric pedestrian stacker Electric high reach truck Horizontal order picker



Lightweight counterbalance FLT Very narrow aisle FLT Heavy duty counterbalance FLT Engine counterbalance heavy duty FLT Frame roll container

Application



Goods In/Out Suitable for heavier vehicles Pedestrian Segregation Traffic Segregation Traffic and Pedestrian Segregation



The Traffic Gate provides a huge return on investment from incident prevention and downtime avoidance as vehicles and floors do not need replacing or repair.

Features and benefits



Large operating handles make the gate easy to lift and close.



The gas assisted lift is designed to ensure a wide range of employees can lift the rails.



The positive lock feature ensures the gate can be lifted and locked securely into position.



Self coloured and UV stabilised for continued visibility and long lasting aesthetics with no repainting.

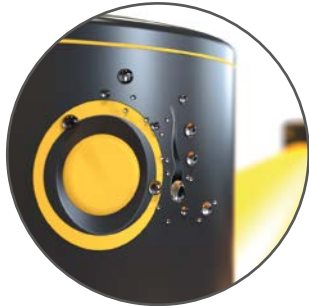

Food safe, wipe-clean, water resistant surface.



Advanced strength polymer, expertly blended for unequalled strength and flexibility.

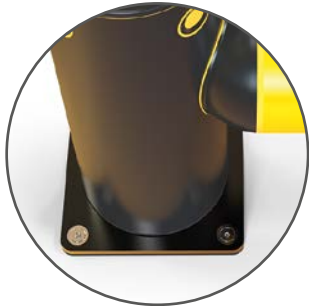

Zinc nickel, electrophoretic coating on base plates as standard, provides advanced protection.



Optional Sign Caps can be applied to the gate posts to provide additional health and safety messages.



Technical Information

How the energy from a vehicle impact is calculated

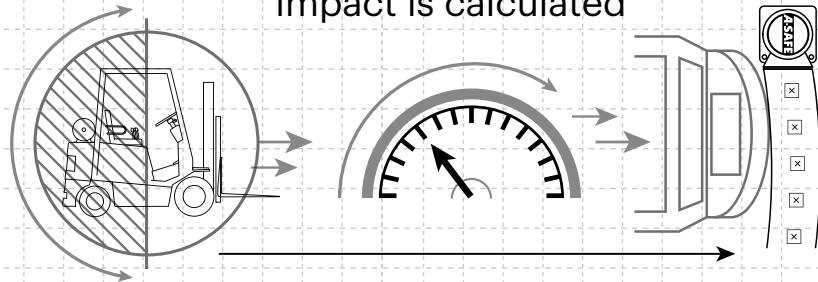

$$\frac{1}{2} \text{ Mass} \times \text{Speed}^2 = \text{Joules}$$

Tested Impact Energy

14,000 Joules

3,230kg vehicle and speed
 x **6.5 mph impact**

Mid Rail 90° Impact on 2000mm Post Centres

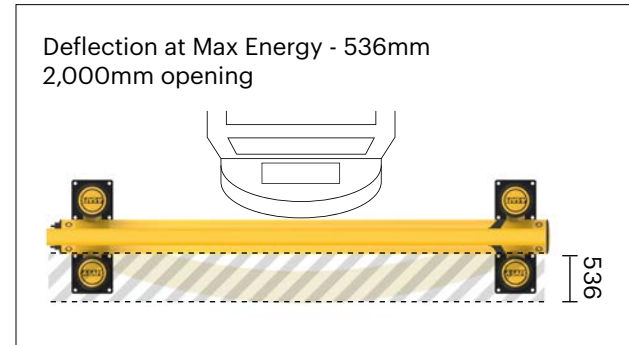

Dimensions (mm)

Side (Open)

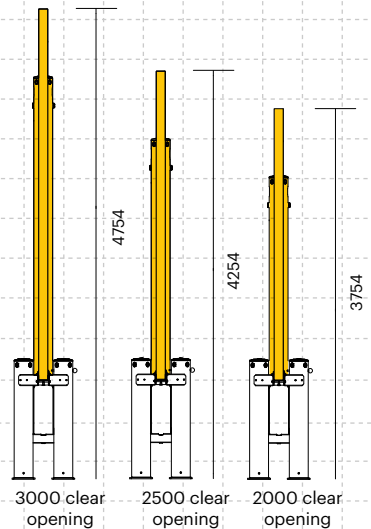

Front
3000mm clear opening

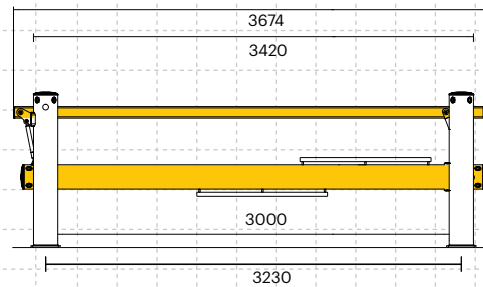

2000mm clear opening

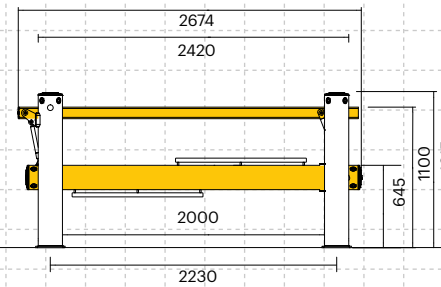

2500mm clear opening

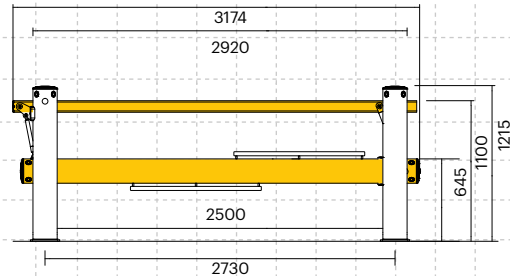

Side (All variants)

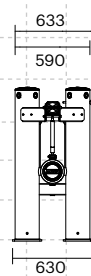

Base (All variants)



Material Properties	MEMAPLEX™
Temperature Range	-10°C to 50°C
Ignition Temperature	370°C to 390°C
Flash Point	350°C to 370°C
Toxicity	Not Hazardous
Chemical Resistance	Excellent - ISO/TR 10358
Weathering Stability (Grey Scale)	5/5*
Light Stability (Blue Wool Scale)	7/8**
Static Rating (Surface Resistivity)	10 ¹⁵ - 10 ¹⁶ Ω
Hygiene Seals	Yes

* Weathering scale 1 is very poor and 5 is excellent
 ** Light stability scale 1 is very poor and 8 is excellent

Post Options



Rail Options



Colour Combinations

*Please note that the RAL and PANTONE colours listed are the closest match to standard A-SAFE colours, but may not be exact matches of the actual product colour and should be used for guidance only.

